

ROC CATALOGUE
CATALOGUE PAC

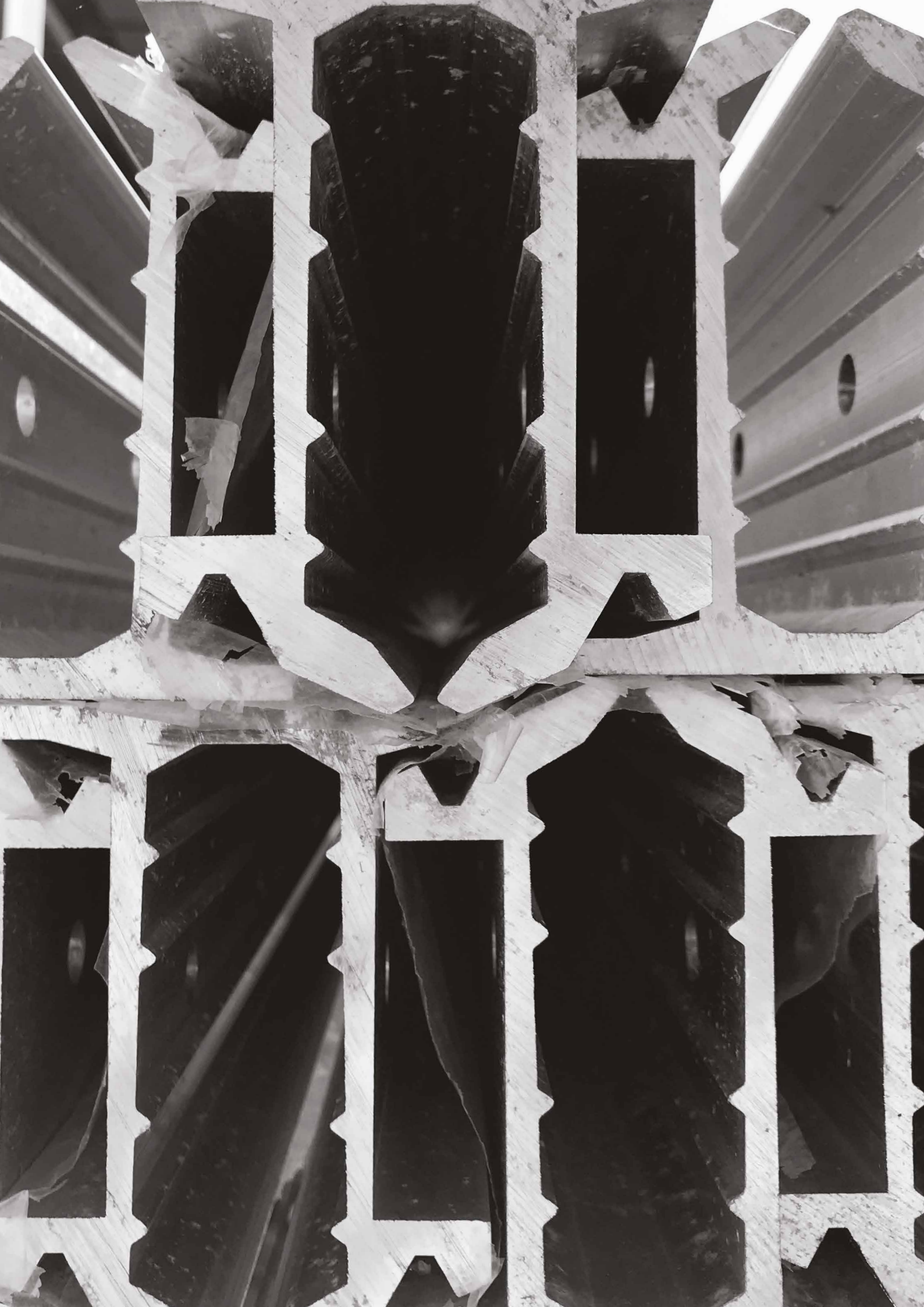



introduction_

INTRODUCTION

GALLAND SAS has developed the first French high-speed rigid rail system (Patented). Approved by Politecnico Di Milano this new design allows to reach speeds of up to 250 km/h. This innovative and powerful solution allows us to implement our expertise. We rely on recognized expertise including studies, installation, and supply of material.

La Société GALLANS SAS a développé le premier système français du rail rigide grande vitesse (Breveté). Validé par Politecnico Di Milano ce nouveau design permet d'atteindre des vitesses de franchissement, jusqu'à 250 km/h. Cette solution innovante et performante nous permet de mettre en œuvre nos savoir-faire. Nous nous appuyons sur une expertise reconnue, concernant notamment : les études, l'installation et la fourniture du matériel.



summary_

SOMMAIRE

Applications <i>Cas d'emploi</i>	6
Basic assemblies <i>Montages types</i>	9
A1-Transition Cat => Roc double insulation <i>A1-Transition Cat=>Pac double isolement</i>	9
A2-Transition Cat => Roc 25 kV <i>A2-Transition Cat=>Pac 25 kV</i>	10
A3-Mid point 750 V / 1500 V double insulation <i>A3-Anticheminement 750 V / 1500 V double isolement</i>	11
A4-Mid point 25 kV <i>A4-Anticheminement 25 kV</i>	12
A5-Transition with bridging connection <i>A5-Transition av connexion de pontage</i>	13
A6-Rotating assembly with insulated bracket <i>A6-Montage rotatif avec bras support isolé</i>	14
A7-Rotating assembly with shock-absorbing insulated bracket <i>A7-Montage rotatif avec bras support amorti isolé</i>	15
A8-Assembly with insulated bracket <i>A8-Montage avec bras support isolé</i>	16
A9-Assembly with shock-absorbing insulated bracket <i>A9-Montage avec bras support amorti isolé</i>	17
A10-Rigid assembly with Omega support 750 V / 1500 V <i>A10-Montage rigide avec support type Omega 750 V / 1500 V</i>	18
A11-Rigid assembly with Omega support 750 V / 1500 V double insulation <i>A11-Montage rigide avec support type Omega 750 V / 1500 V double isolement</i>	19
A12-Rigid assembly with straight support <i>A12-Montage rigide avec support droit</i>	20
A13-Rigid assembly with straight support 750 V / 1500 V double insulation <i>AA13-Montage rigide avec support droit 750 V / 1500 V double isolement</i>	21
A14-Rigid assembly with reduced space Omega support 750 V / 1500 V <i>A14-Montage rigide Omega 750 V / 1500 V encombrement réduit</i>	22
A15-Rigid assembly with reduced space 750 V / 1500 V double insulation <i>A15-Montage rigide Omega 750 V / 1500 V double isolement, encombrement réduit</i>	23
A16-Expansion joint assembly <i>A16-Montage avec joint de dilatation</i>	24
A17-Section insulator assembly <i>A17-Montage avec isolateur de section</i>	25



Components <i>Pièces détachées</i>	26
Rigid bar 110 <i>Profil 110</i>	26
Joint plates <i>Eclisses</i>	26
Transition bar 110 <i>Profil de transition 110</i>	27
Anchoring bar 110 <i>Barre d'ancrage 110</i>	27
Ramp bar 110 <i>Barre de rampe 110</i>	27
Fixing clamp <i>Bride de suspension fixe</i>	28
Sliding clamp <i>Bride de suspension glissante</i>	28
Earthing clamp with stirrup <i>Bride de mise au rail</i>	28
Electric power feed <i>Bride pour une connexion</i>	29
Double electric power feed <i>Bride pour deux connexions</i>	29
Bridging connection <i>Connexion de pontage</i>	29
Mid point clamp <i>Bloc anticheminement</i>	30
Mid point clamp - 4 slings <i>Bloc anticheminement - 4 élingues</i>	30
Anchoring clamp <i>Bloc d'ancrage</i>	30
Anchoring sling 25 kV <i>Élingue d'ancrage 25 kV</i>	31
Anchoring sling 25 kV <i>Élingue d'ancrage 25 kV</i>	31
Double insulating anchoring sling <i>Élingue d'ancrage double isolement</i>	32
Protective cover <i>Capot de protection</i>	32
Others items <i>Divers</i>	
Certifications <i>Certifications</i>	34
Contacts <i>Contacts</i>	35

Applications

Cas d'emploi

MONTAGE TYPE <i>Montage type</i>	DEPOT	<160KM/H	160 - 250 KM/H
A1-Transition assembly Cat>Roc 750 V/1500 V <i>A1-Montage Transition Cat>Pac 750 V/1500 V</i>	X	X	
A2-Transition assembly Cat>Roc 25 kV <i>A2-Montage Transition Cat>Pac 25 kV</i>	X	X	X
A3-Mid point assembly 750 V/1500 V <i>A3-Montage anticheminement 750 V/1500 V</i>	X	X	
A4-Mid point assembly 25 kV <i>A4-Montage anticheminement 25 kV</i>	X	X	X
A5-Transition assembly with bridging connection <i>A5-Montage Transition avec connexion de pontage</i>	X	X	X
A6-Transition assembly with bridging connection 1500 V <i>A6-Montage Transition avec connexion de pontage 1500 V</i>	X	X	
A7-Assembly with rigid insulated bracket 750 V/1500 V <i>A7-Montage rigide avec bras support 750 V/1500 V</i>	X	X	X
A8-Assembly with rigid insulated bracket 25 kV <i>A8-Montage rigide avec bras support 25 kV</i>	X	X	
A9-Assembly with shock absorber insulated bracket 25 kV <i>A9-Montage souple avec bras support amorti 25 kV</i>	X	X	X
A10-Rigid assembly with Omega support 750 V/1500 V <i>A10-Montage rigide avec support type Omega 750 V/1500 V</i>	X	X	
A11-Rigid assembly with Omega support 750 V/1500 V double insulation <i>A11-Montage rigide type Omega 750 V/1500 V double isolement</i>	X	X	
A12-Rigid assembly with straight support 750 V/1500 V <i>A12-Montage rigide avec support droit 750 V/1500 V</i>	X	X	
A13-Rigid assembly with straight support 750 V/1500 V double insulation <i>A13-Montage rigide avec support droit 750 V/1500 V double isolement</i>	X	X	
A14-Rigid assembly with Omega support for reduce space <i>A14-Montage rigide avec support Omega encombrement réduit</i>	X	X	
A15-Rigid assembly with Omega support and double insulation <i>A15-Montage rigide avec support Omega encombrement réduit double isolement</i>	X	X	
A16-Expansion joint assembly <i>A16-Montage joint de dilatation</i>	X	X	X
A17-Section insulator assembly <i>A17-Montage isolateur de section</i>	X	X	X

NOMINAL VOLTAGE <i>Tensions nominales</i>			
750 V	X	X	
1500 V	X	X	
25 kV	X	X	X

Basic assemblies_

Montages types

A1-Transition Cat => Roc double insulation

A1-Transition Cat => Pac double isolement

This assembly type allows to make the transition between the flexible catenary and the rigid overhead catenary.

Ce montage type permet d'assurer la transition entre une caténaire flexible et une caténaire rigide.

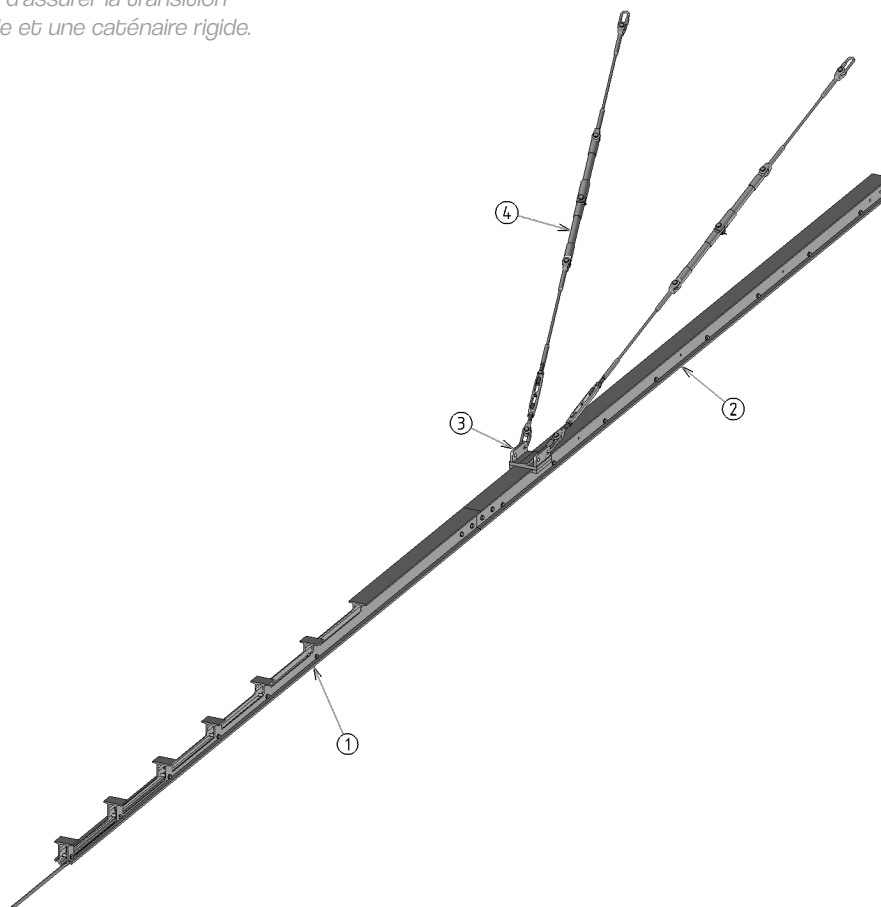

ITEM <i>Repère</i>	NAME <i>Désignation</i>	REF <i>Référence</i>
1	Transition bar <i>Barre de transition</i>	RIG0208/RIG0210/RIG0212
2	Anchoring bar <i>Barre d'ancrage</i>	RIG0308/RIG0310/RIG0312
3	Anchoring clamp <i>Bloc d'ancrage</i>	JG3639/201
4	Anchoring sling <i>Ensemble élingue d'ancrage</i>	ANC4C10-0203

DEPOT	<160 KM/H	>160 - 250 KM/H	750 V	1500 V	25 KV
X	X		X	X	

Basic assemblies_

Montages types

A2-Transition Cat => Roc 25 kV

A2-Transition Cat => Pac 25 kV

This assembly type allows to make the transition between the flexible catenary and the rigid overhead catenary.

Ce montage type permet d'assurer la transition entre une caténaire flexible et une caténaire rigide.

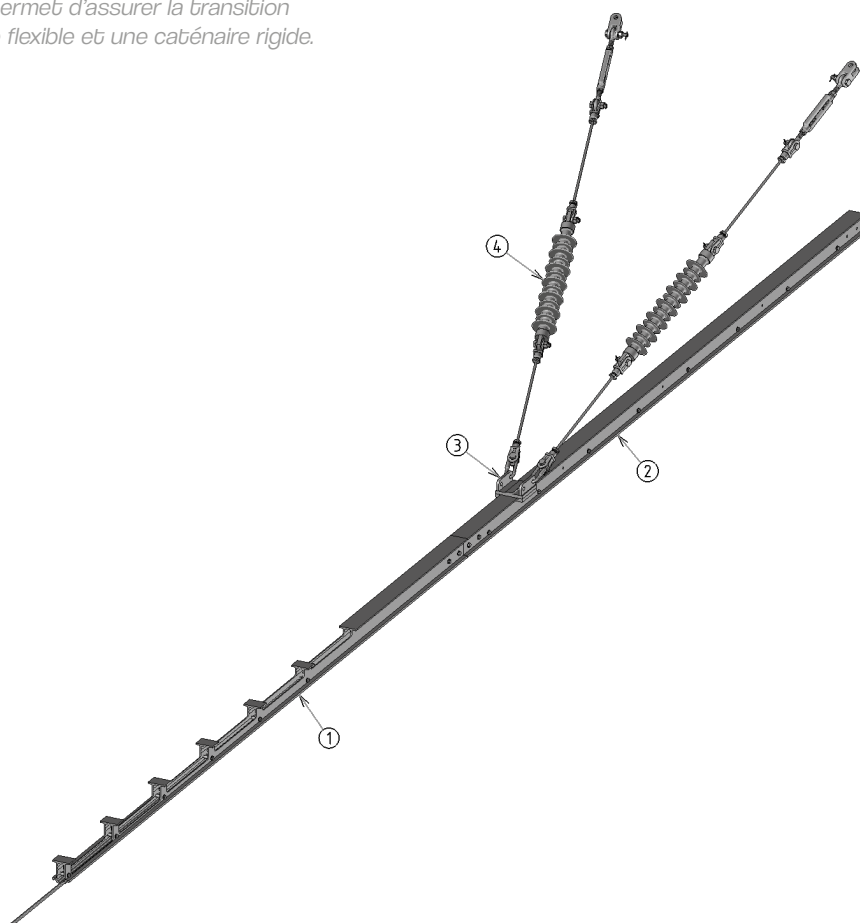

ITEM <i>Repère</i>	NAME <i>Désignation</i>	REF <i>Référence</i>
1	Transition bar <i>Barre de transition</i>	RIG0208/RIG0210/RIG0212
2	Anchoring bar <i>Barre d'ancrage</i>	RIG0308/RIG0310/RIG0312
3	Anchoring clamp <i>Bloc d'ancrage</i>	JG3639/201
4	Anchoring sling <i>Ensemble élingue d'ancrage</i>	ANC1C10-0101/-0102

DEPOT	<160 KM/H	>160 - 250 KM/H	750 V	1500 V	25 KV
X	X	X			X

Basic assemblies_

Montages types

A3-Mid point 750 V / 1500 V double insulation

A3-Anticheminement 750 V / 1500 V double isolement

This assembly type allows to block the rigid bar on the fixed point.

Ce montage type permet de bloquer le rail rigide au point d'anticheminement.

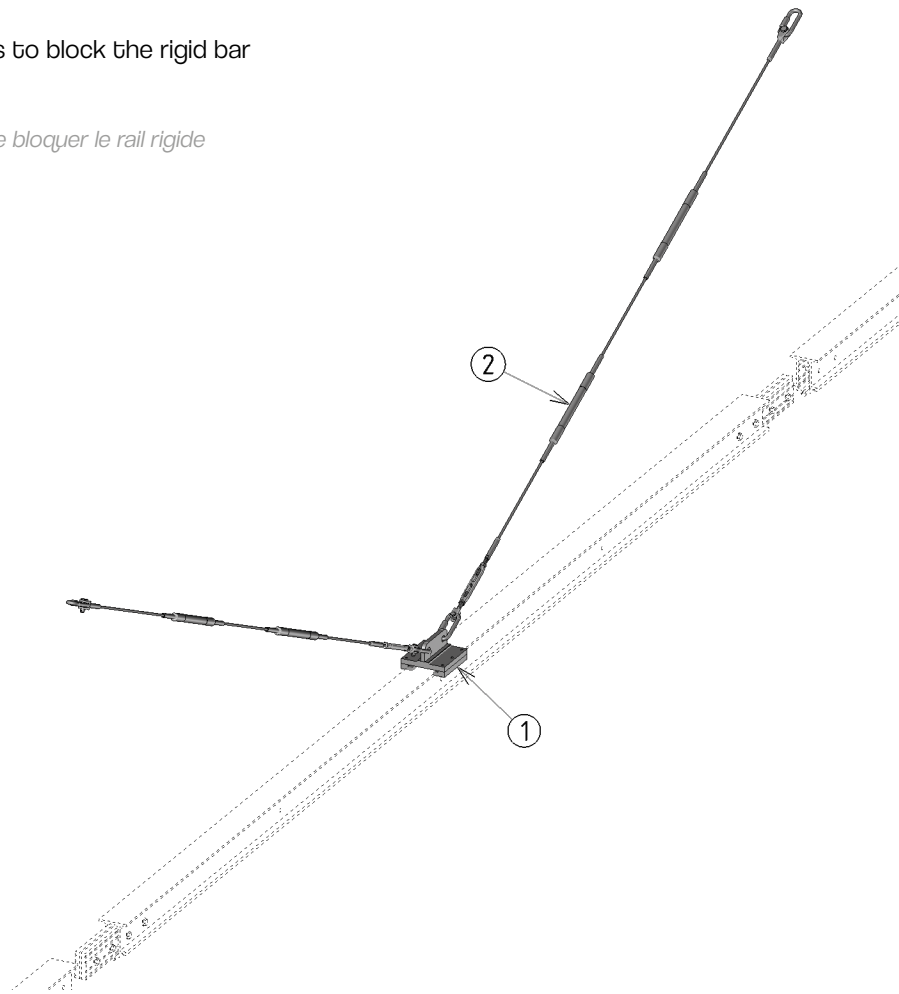

ITEM <i>Repère</i>	NAME <i>Désignation</i>	REF <i>Référence</i>
1	Mid point clamp <i>Bloc d'anticheminement</i>	JG3639/101
2	Anchoring sling <i>Elingue d'ancrage</i>	ANC4C6-0301

DEPOT	<160 KM/H	>160 - 250 KM/H	750 V	1500 V	25 KV
X	X		X	X	

Basic assemblies_

Montages types

A4-Mid point 25 kV

A4-Anticheminement 25 kV

This assembly type allows to block the rigid bar on the fixed point.

Ce montage type permet de bloquer le rail rigide au point d'anticheminement.

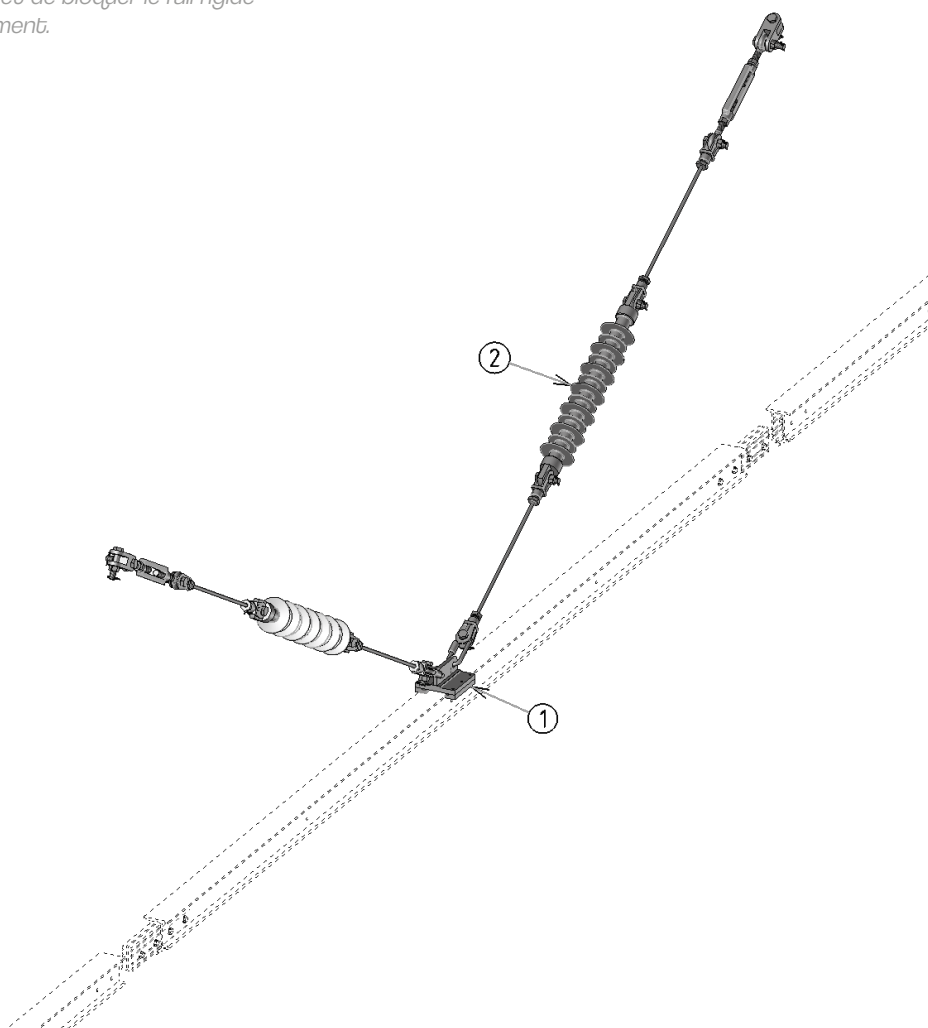

ITEM <i>Repère</i>	NAME <i>Désignation</i>	REF <i>Référence</i>
1	Mid point clamp <i>Bloc d'anticheminement</i>	JG3639/101
2	Anchoring sling 25 kV <i>Ensemble élingue d'ancrage 25 kV</i>	ANC1C10-0101/-0102

DEPOT	<160 KM/H	>160 - 250 KM/H	750 V	1500 V	25 KV
X	X	X			X

Basic assemblies_

Montages types

A5-Transition with bridging connection

A5-Transition avec connexion de pontage

This assembly type allows to keep the electrical performances between two transition rigid bars.

Ce montage type permet d'assurer une continuité électrique entre deux transitions de rail rigide.

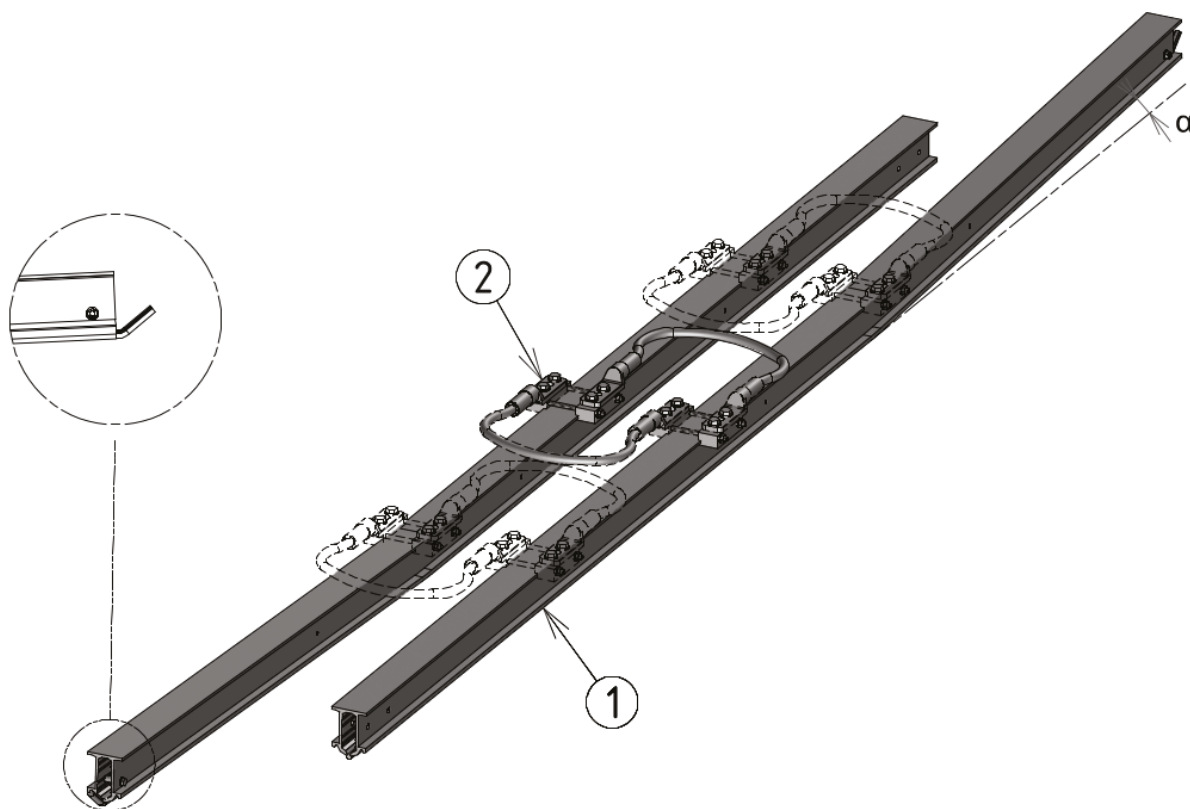

ITEM <i>Repère</i>	NAME <i>Désignation</i>	REF <i>Référence</i>
1	Ramp bar <i>Barre de rampe</i>	RIG0404
2	Connection clamp assembly <i>Ensemble bride de connexion</i>	n x JG3690/102

DEPOT	<160 KM/H	>160 - 250 KM/H	750 V	1500 V	25 KV
X	X	X	X	X	X

Basic assemblies_

Montages types

A6-Rotating assembly with insulated bracket

A6-Montage rotatif avec bras support isolé

This assembly allows to install the rigid bar with an insulated rotating bracket.

Ce montage type permet d'installer le rail rigide avec un bras support rotatif isolé.

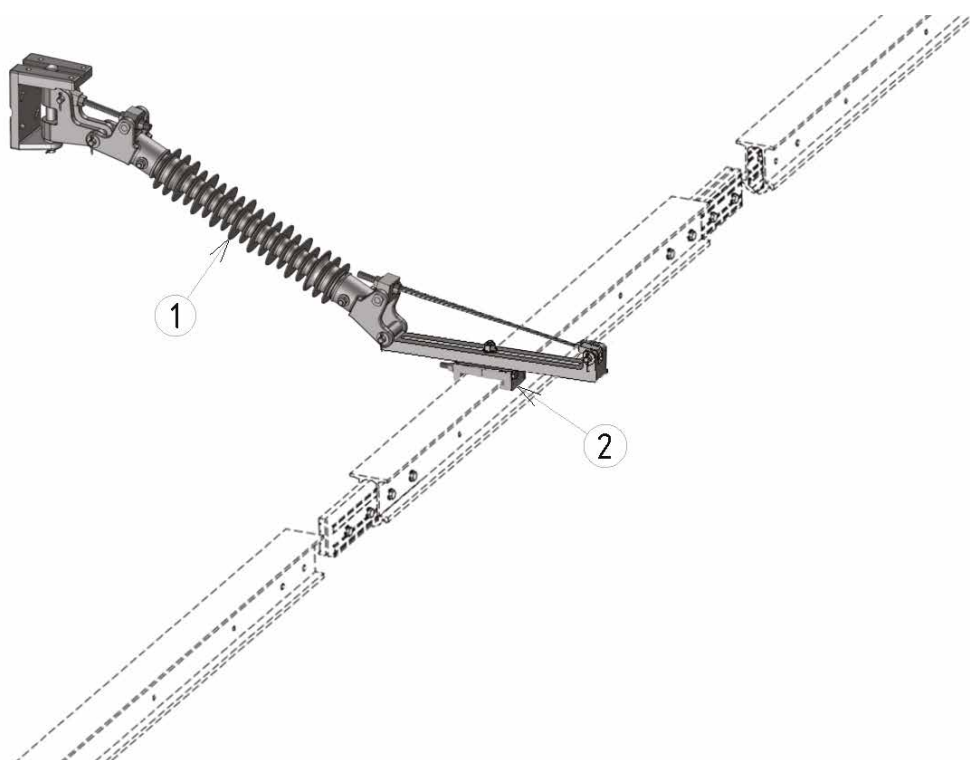

ITEM <i>Repère</i>	NAME <i>Désignation</i>	REF <i>Référence</i>
1	Rotating bracket <i>Bras support rotatif</i>	JG3342/202
2	Fixing clamp <i>Pince de suspension fixe</i>	JG3853/201

DEPOT	<160 KM/H	>160 - 250 KM/H	750 V	1500 V	25 KV
X	X		X	X	X

Basic assemblies_

Montages types

A7-Rotating assembly with shock-absorbing insulated bracket

A7-Montage rotatif avec bras support amorti isolé

This assembly allow to install the rigid bar with a shock-absorbing insulated rotating bracket.

Ce montage type permet d'installer le rail rigide avec un bras support amorti rotatif isolé.

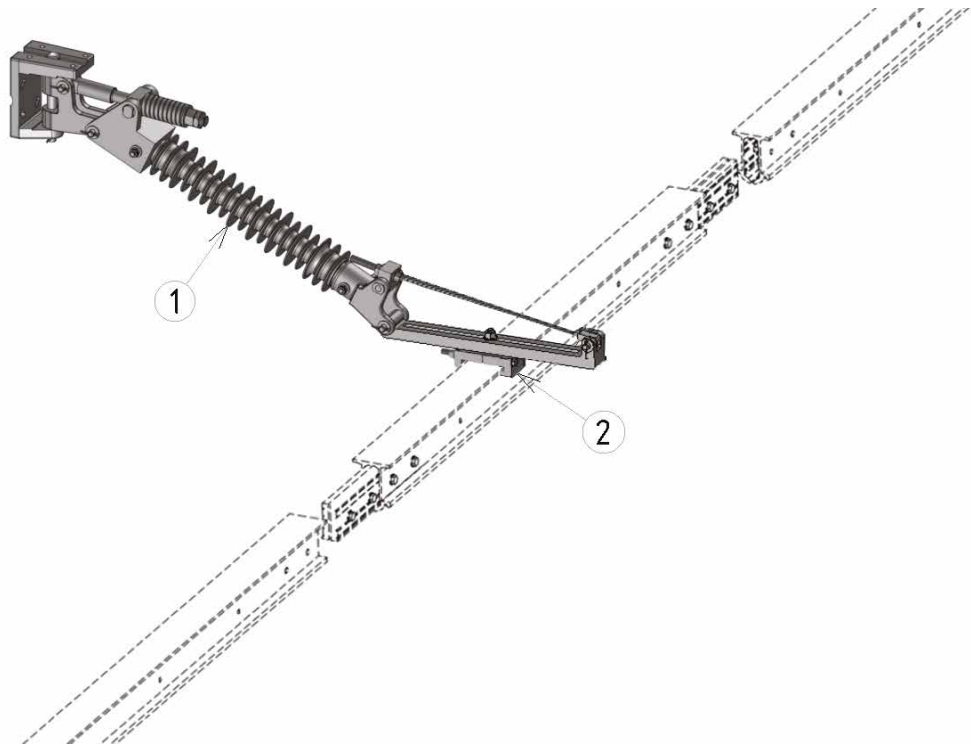

ITEM <i>Repère</i>	NAME <i>Désignation</i>	REF <i>Référence</i>
1	Shock-absorbing rotating bracket <i>Bras support amorti rotatif</i>	JG3342/102
2	Fixing clamp <i>Pince de suspension fixe</i>	JG3853/201

DEPOT	<160 KM/H	>160 - 250 KM/H	750 V	1500 V	25 KV
X	X	X	X	X	X

Basic assemblies_

Montages types

A8-Assembly with insulated bracket

A8-Montage avec bras support isolé

This assembly allows to install the rigid bar with an insulated bracket.

Ce montage type permet d'installer le rail rigide avec un bras support isolé.

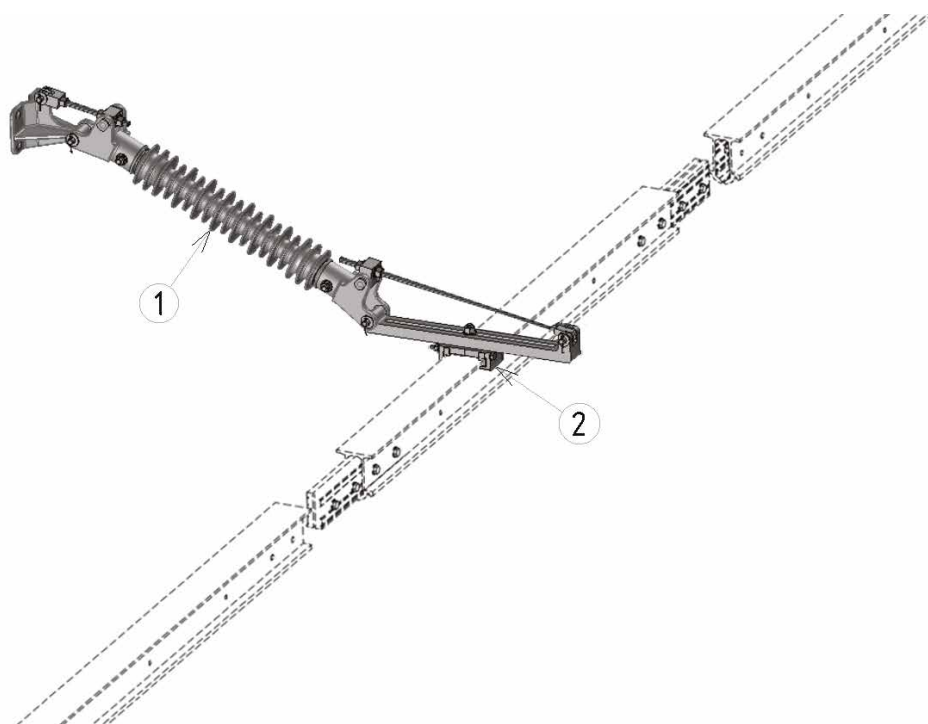

ITEM <i>Repère</i>	NAME <i>Désignation</i>	REF <i>Référence</i>
1	Bracket <i>Bras support</i>	JG3632/202
2	Sliding clamp <i>Pince de suspension glissante</i>	JG3853/202

DEPOT	<160 KM/H	>160 - 250 KM/H	750 V	1500 V	25 KV
X	X		X	X	X

Basic assemblies_

Montages types

A9-Assembly with shock-absorbing insulated bracket

A9-Montage avec bras support amorti isolé

This assembly allows to install the rigid bar with a shock-absorbing insulated bracket.

Ce montage type permet d'installer le rail rigide avec un bras support amorti isolé.

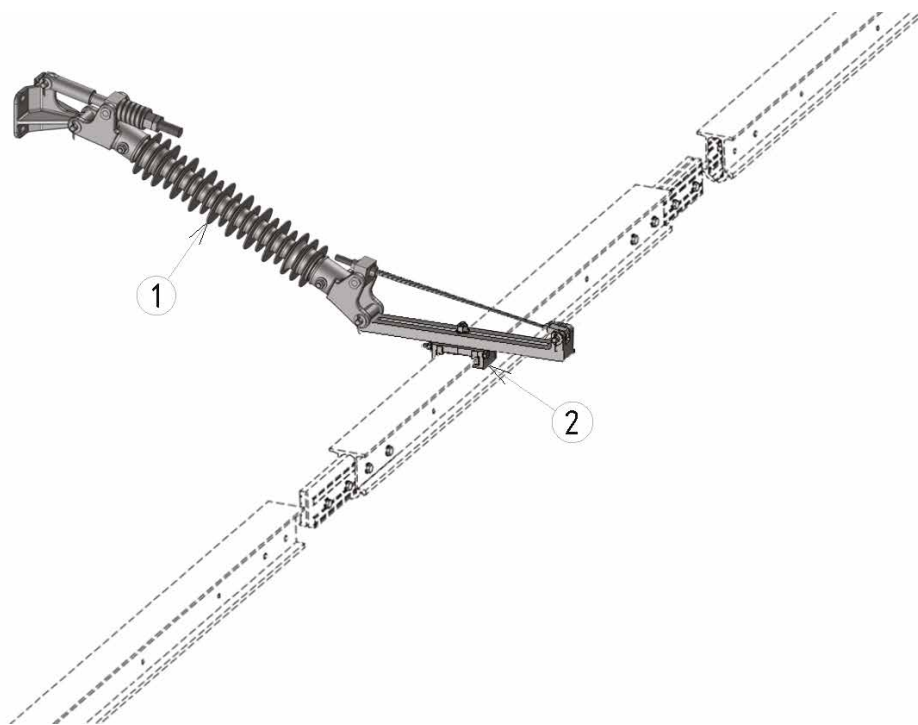

ITEM <i>Repère</i>	NAME <i>Désignation</i>	REF <i>Référence</i>
1	Shock-absorbing bracket <i>Bras support rigide amorti</i>	RIG0625
2	Sliding clamp <i>Pince de suspension glissante</i>	JG3853/202

DEPOT	<160 KM/H	>160 - 250 KM/H	750 V	1500 V	25 KV
X	X	X	X	X	X

Basic assemblies_

Montages types

A10-Rigid assembly with Omega support 750 V / 1500 V

A10-Montage rigide avec support
type Omega 750 V / 1500 V

This assembly type allows to install the rigid bar
with a fixed insulated support.

*Ce montage type permet d'installer le rail rigide
avec un support fixe isolé.*

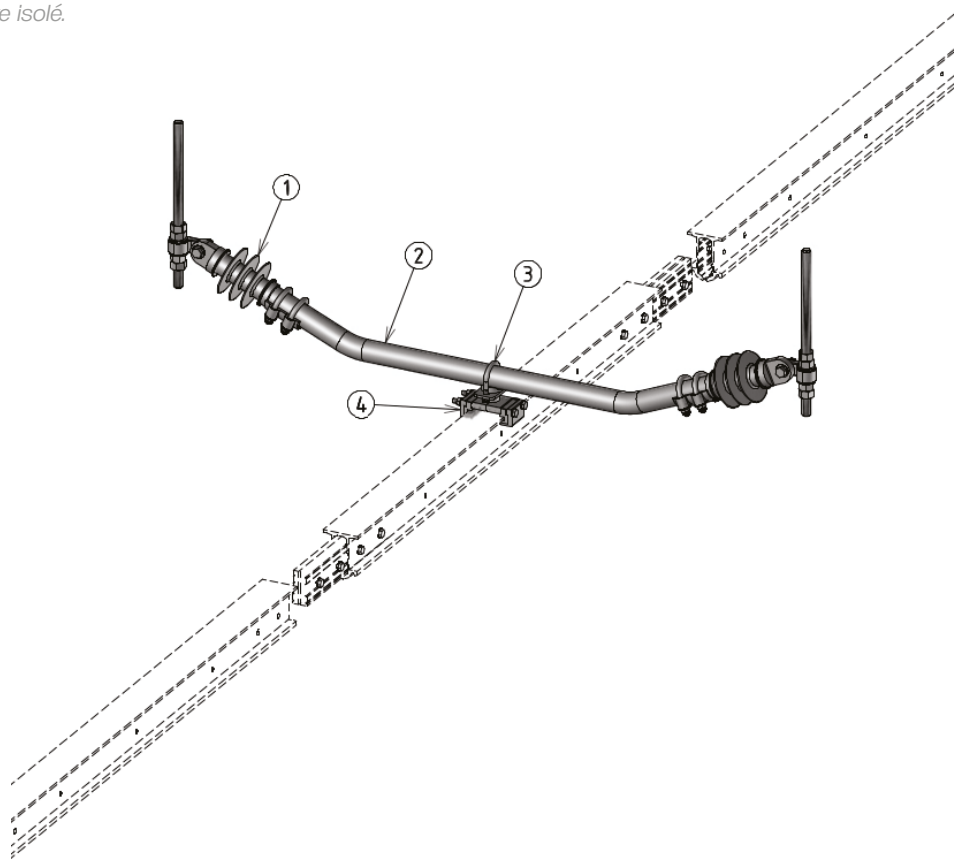

ITEM <i>Repère</i>	NAME <i>Désignation</i>	REF <i>Référence</i>
1	Composite insulator 750/1500 V <i>Isolateur synthétique 750/1500 V</i>	N52034
2	Omega support <i>Support fixe type Omega</i>	
3	Fastener for clamp <i>Attache pour bride</i>	JG3913/101
4	Sliding clamp <i>Pince de suspension glissante</i>	JG3853/202

DEPOT	<160 KM/H	>160 - 250 KM/H	750 V	1500 V	25 KV
X	X		X	X	

Basic assemblies_

Montages types

A11-Rigid assembly with Omega support 750 V / 1500 V double insulation

A11-Montage rigide avec support
type Omega 750 V / 1500 V double isolement

This assembly type allows to install the rigid bar
with a fixed support.

*Ce montage type permet d'installer le rail rigide
avec un support fixe.*

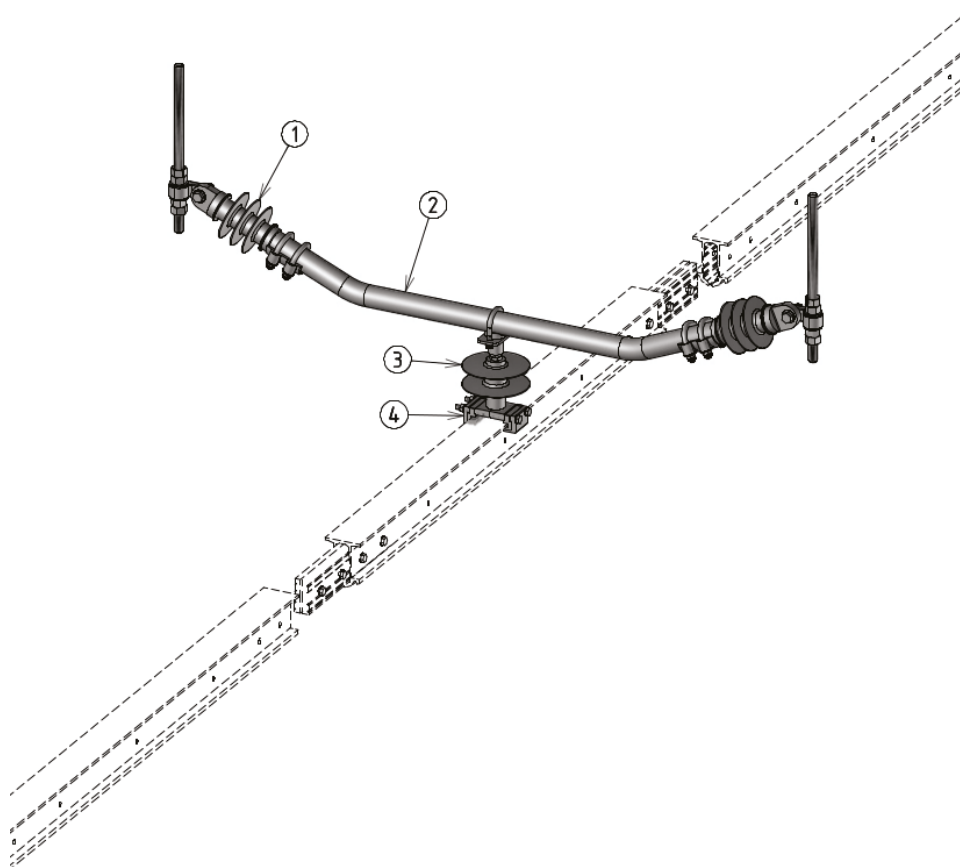

ITEM <i>Repère</i>	NAME <i>Désignation</i>	REF <i>Référence</i>
1	Composite insulator 750/1500 V <i>Isolateur synthétique 750/1500 V</i>	N52034
2	Omega support <i>Support fixe type Omega</i>	
3	Insulated fastener for clamp <i>Attache isolée pour bride</i>	JG3913/201
4	Sliding clamp <i>Pince de suspension glissante</i>	JG3853/202

DEPOT	<160 KM/H	>160 - 250 KM/H	750 V	1500 V	25 KV
X	X		X	X	

Basic assemblies_

Montages types

A12-Rigid assembly with straight support

A12-Montage rigide avec support droit

This assembly type allows to install the rigid bar with a straight fixed support.

Ce montage type permet d'installer le rail rigide avec un support fixe droit.

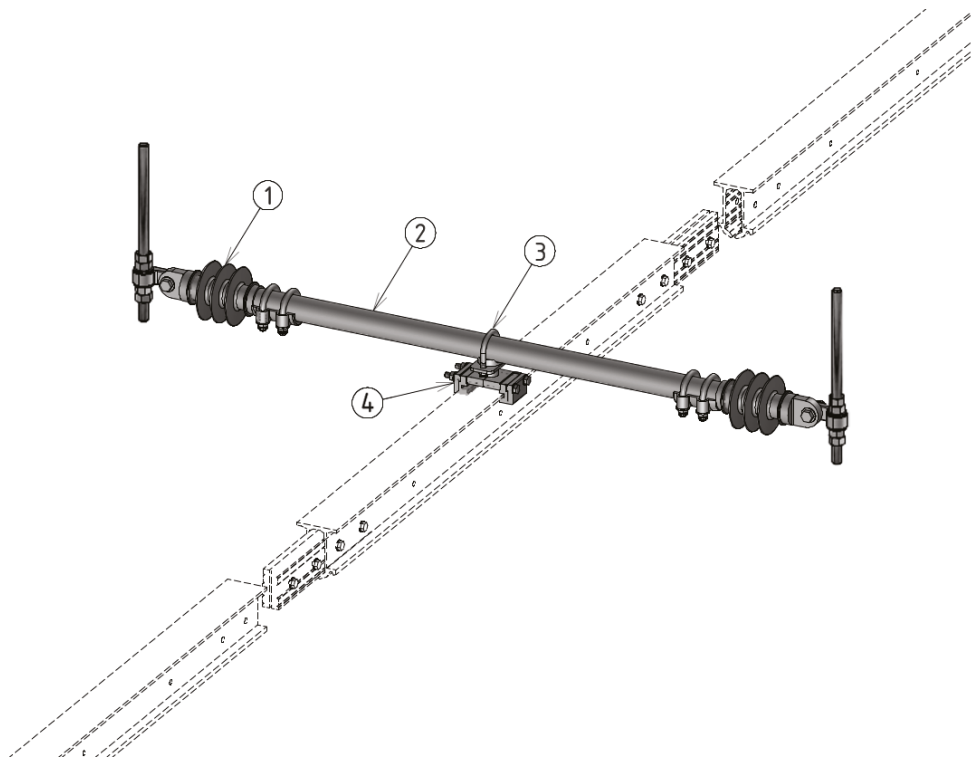

ITEM <i>Repère</i>	NAME <i>Désignation</i>	REF <i>Référence</i>
1	Composite insulator 750/1500V <i>Isolateur synthétique 750/1500V</i>	N52034
2	Straight fixed support <i>Support fixe droit</i>	
3	Fastener for clamp <i>Attache pour bride</i>	JG3913/101
4	Sliding clamp <i>Pince de suspension glissante</i>	JG3853/202

DEPOT	<160 KM/H	>160 - 250 KM/H	750 V	1500 V	25 KV
X	X		X	X	

Basic assemblies_

Montages types

A13-Rigid assembly with straight support 750 V / 1500 V double insulation

A13-Montage rigide avec support droit 750 V / 1500 V double isolement

This assembly type allows to install the rigid bar with a straight fixed support with double insulation.

Ce montage type permet d'installer le rail rigide avec un support fixe droit avec double isolement.

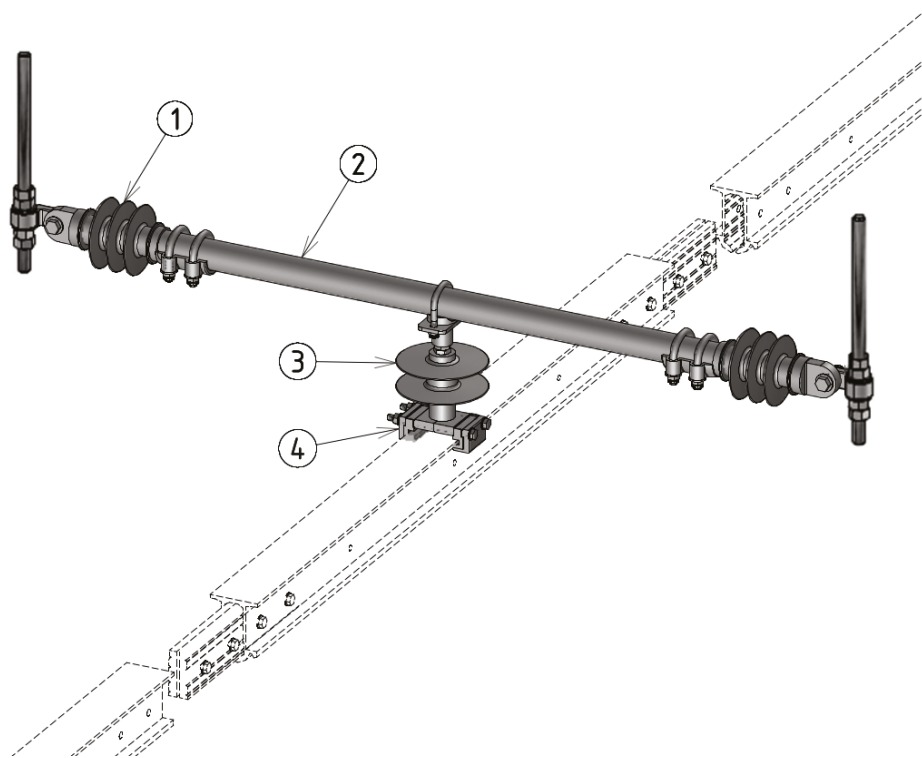

ITEM <i>Repère</i>	NAME <i>Désignation</i>	REF <i>Référence</i>
1	Composite insulator 750/1500V <i>Isolateur synthétique 750/1500V</i>	N52034
2	Straight fixed support <i>Support fixe droit</i>	
3	Insulated fastener for clamp <i>Attache isolée pour bride</i>	JG3913/201
4	Sliding clamp <i>Pince de suspension glissante</i>	JG3853/202

DEPOT	<160 KM/H	>160 - 250 KM/H	750 V	1500 V	25 KV
X	X		X	X	

Basic assemblies_

Montages types

A14-Rigid assembly with reduced space Omega support 750 V / 1500 V

A14-Montage rigide Omega
750 V / 1500 V encombrement réduit

This assembly type allows to install the rigid bar with an Omega support for reduced space.

Ce montage type permet d'installer le rail rigide avec un support rigide Omega encombrement réduit.

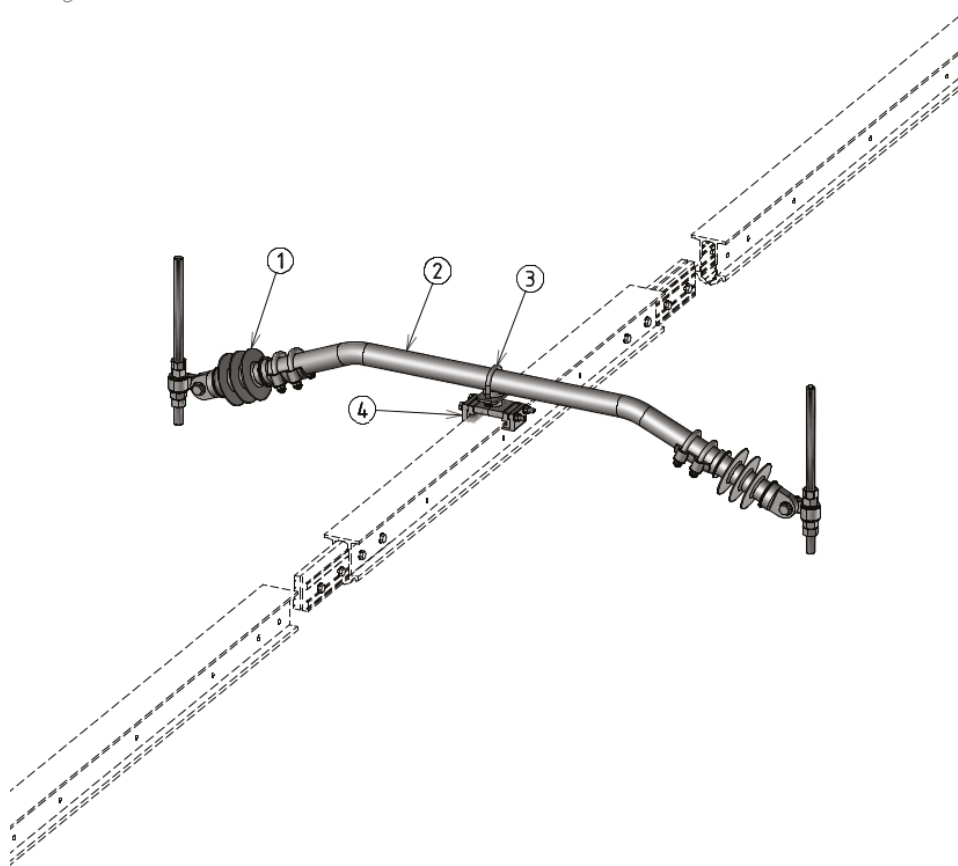

ITEM <i>Repère</i>	NAME <i>Désignation</i>	REF <i>Référence</i>
1	Composite insulator 750/1500 V <i>Isolateur synthétique 750/1500 V</i>	N52034
2	Omega support <i>Support fixe type Omega</i>	
3	Fastener for clamp <i>Attache pour bride</i>	JG3913/101
4	Sliding clamp <i>Pince de suspension glissante</i>	JG3853/202

DEPOT	<160 KM/H	>160 - 250 KM/H	750 V	1500 V	25 KV
X	X		X	X	

Basic assemblies_

Montages types

A15-Rigid assembly with reduced space 750 V / 1500 V double insulation

A15-Montage rigide Omega 750 V / 1500 V
double isolement, encombrement réduit

This assembly type allows to install the rigid bar with an Omega support for reduced space.

Ce montage type permet d'installer le rail rigide avec un support rigide Omega encombrement réduit.

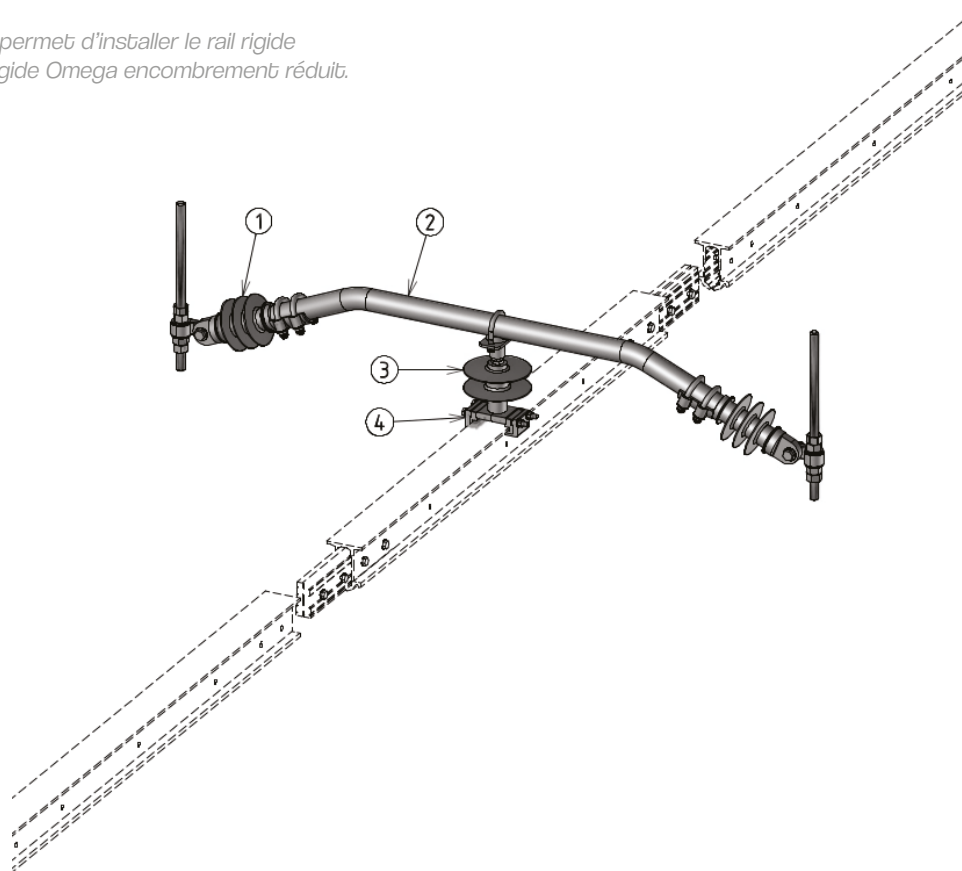

ITEM <i>Repère</i>	NAME <i>Désignation</i>	REF <i>Référence</i>
1	Composite insulator 750/1500V <i>Isolateur synthétique 750/1500V</i>	N52034
2	Omega support <i>Support fixe type Omega</i>	
3	Insulated fastener for clamp <i>Attache isolée pour bride</i>	JG3913/201
4	Sliding clamp <i>Pince de suspension glissante</i>	JG3853/202

DEPOT	<160 KM/H	>160 - 250 KM/H	750 V	1500 V	25 KV
X	X		X	X	

Basic assemblies_

Montages types

A16-Expansion joint assembly

A16-Montage avec joint de dilatation

This assembly type allows to absorb the rigid bar expansion (1 m).

Ce montage type permet d'assurer la dilatation du profil (1 m).

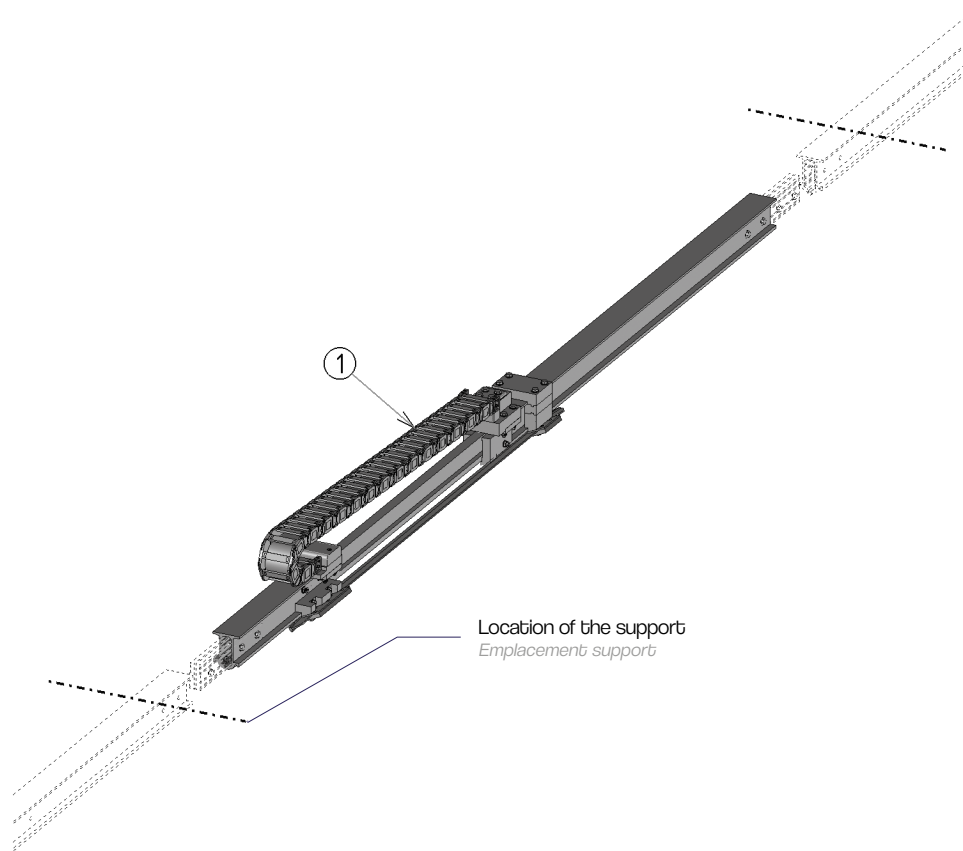

ITEM <i>Repère</i>	NAME <i>Désignation</i>	REF <i>Référence</i>
1	Expansion joint assembly <i>Ensemble joint de dilatation</i>	JG3203

DEPOT	<160 KM/H	>160 - 250 KM/H	750 V	1500 V	25 KV
X	X	X	X	X	X

Basic assemblies_

Montages types

A17-Section insulator assembly

A17-Montage avec isolateur de section

This assembly type allows to make the electrical segmentation on the Rigid Overhead Catenary 750 V / 1500 V / 25 kV.

Ce montage type permet de séparer électriquement deux sections de caténaire rigide : 750 V / 1500 V / 25kV.

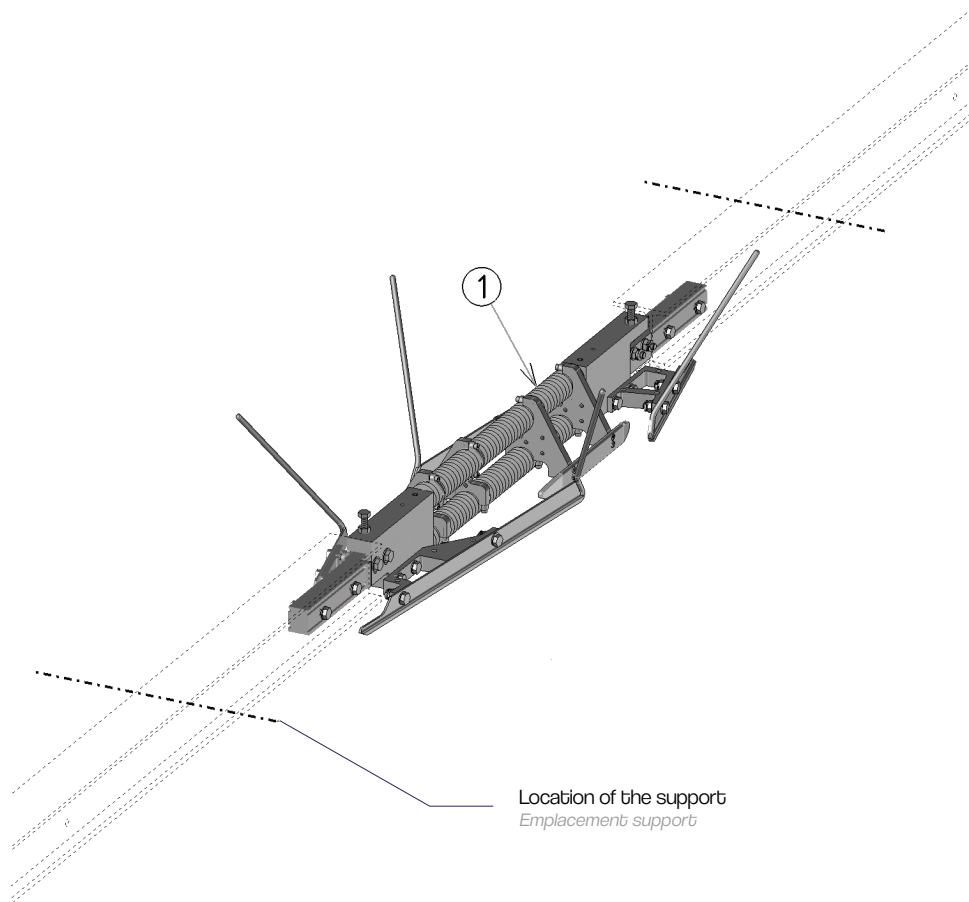

ITEM <i>Repère</i>	NAME <i>Désignation</i>	REF <i>Référence</i>
1	Section insulator assembly <i>Ensemble isolateur</i>	JG3712

DEPOT	<160 KM/H	>160 - 250 KM/H	750 V	1500 V	25 KV
X	X	X	X	X	X

Components_

Pièces détachées

Rigid bar 110

Profil 110

RIG0108 (L = 8m)

RIG0110 (L = 10m)

RIG0112 (L = 12m)

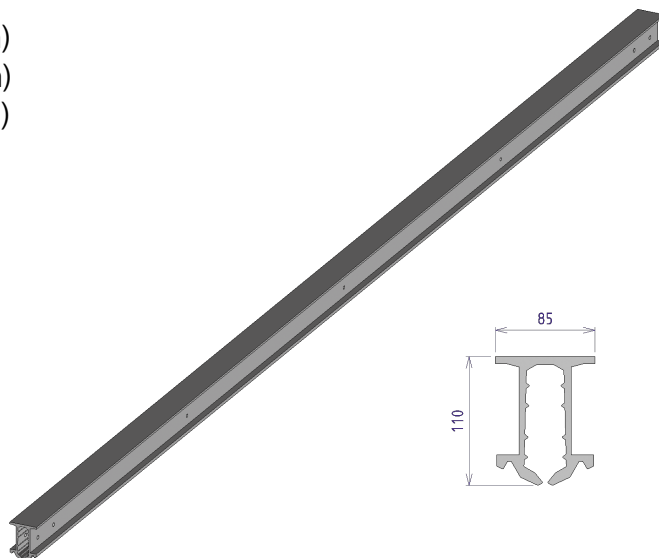

Joint plates

Eclisses

RIG0500

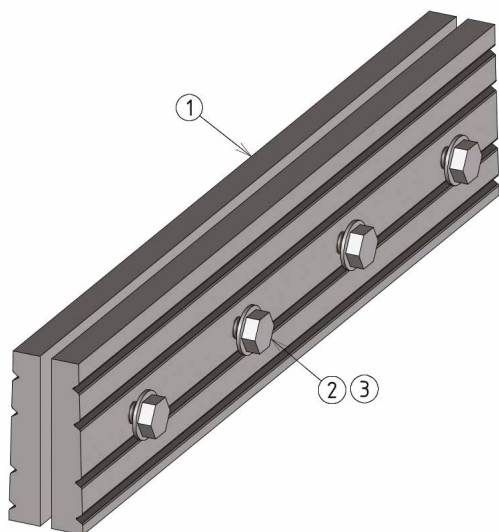

ITEM <i>Repère</i>	QTY <i>Nombre</i>	NAME <i>Désignation</i>	REF <i>Référence</i>
1	2	Joint plates <i>Eclisse</i>	RIG0500-1
2	8	Screw M10 <i>Vis M10</i>	900478
3	8	Washer CS10 <i>Rondelle CS10</i>	770461

Components_

Pièces détachées

Transition bar 110

Profil de transition 110

RIG0208 (L = 8m)

RIG0210 (L = 10m)

RIG0212 (L = 12m)

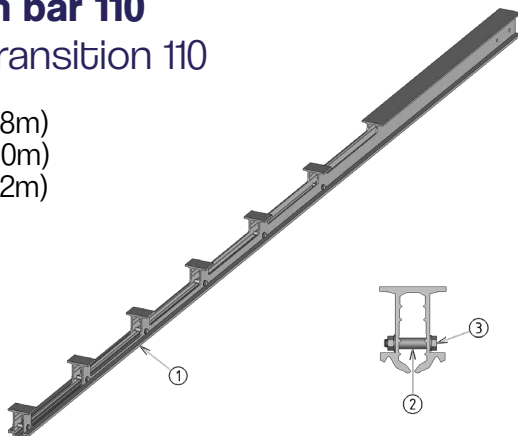

ITEM <i>Repère</i>	QTY <i>Nombre</i>	NAME <i>Désignation</i>	REF <i>Référence</i>
1	1	Transition bar 110-R4 <i>Barre de transition 110-R4</i>	RIG0208-1 RIG0210-1 RIG0212-1
2	7	Strut <i>Entretoise</i>	JG3647/101
3	7	Bolt M10 <i>Boulon M10</i>	

Anchoring bar 110

Barre d'ancrage 110

RIG0308 (L = 8m)

RIG0310 (L = 10m)

RIG0312 (L = 12m)

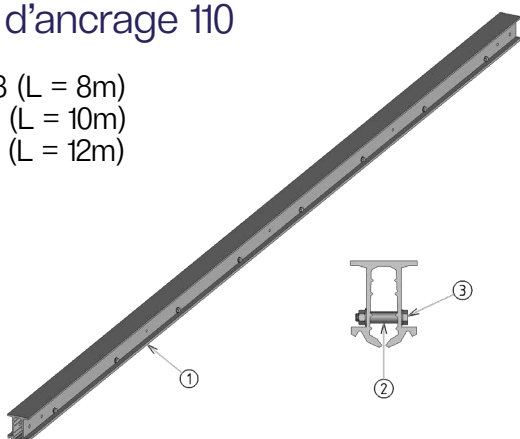

ITEM <i>Repère</i>	QTY <i>Nombre</i>	NAME <i>Désignation</i>	REF <i>Référence</i>
1	1	Anchoring bar 110-R4 <i>Barre de d'ancrage 110-R4</i>	RIG0308-1 RIG0310-1 RIG0312-1
2	8	Strut <i>Entretoise</i>	JG3647/101
3	8	Bolt M10 <i>Boulon M10</i>	

Ramp bar 110

Barre de rampe 110

RIG0404 (L = 4m)

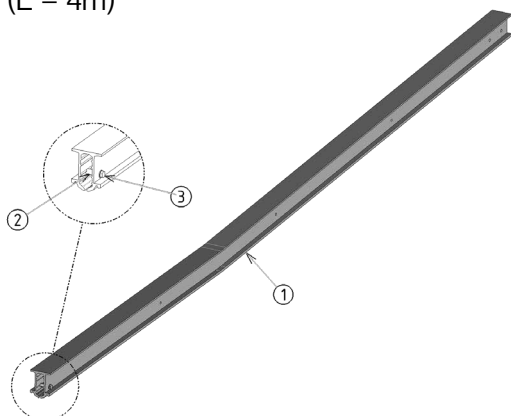

ITEM <i>Repère</i>	QTY <i>Nombre</i>	NAME <i>Désignation</i>	REF <i>Référence</i>
1	1	Bar ramp 110-R4 <i>Barre de rampe 110-R4</i>	RIG0404-1
2	1	Strut <i>Entretoise</i>	JG3647/101
3	1	Bolt M10 <i>Boulon M10</i>	

Components_

Pièces détachées

Fixing clamp

Pince de suspension fixe

JG3853/201

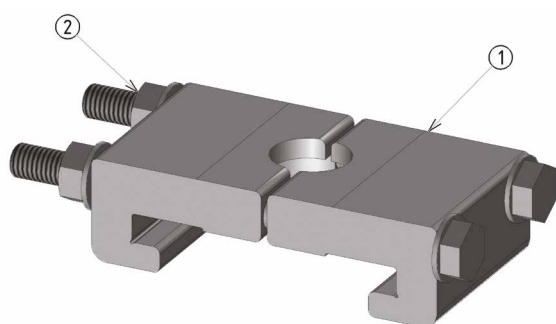

ITEM <i>Repère</i>	QTY <i>Nombre</i>	NAME <i>Désignation</i>	REF <i>Référence</i>
1	2	Half-clap <i>Demi-pince</i>	JG3853-5
2	2	Bolt <i>Boulon</i>	

Sliding clamp

Pince de suspension glissante

JG3853/202

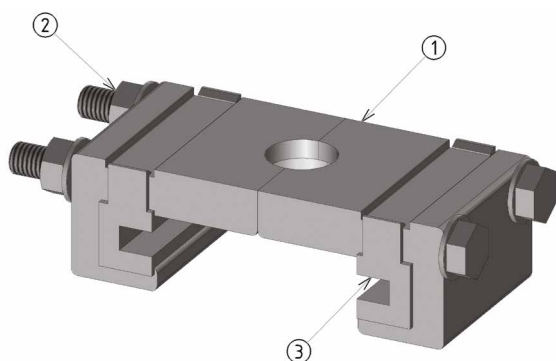

ITEM <i>Repère</i>	QTY <i>Nombre</i>	NAME <i>Désignation</i>	REF <i>Référence</i>
1	2	Half-clap <i>Demi-pince</i>	JG3853-5
2	2	Bolt <i>Boulon</i>	
3	2	Slide <i>Guide</i>	JG3853-6

Earthing clamp with stirrup

Bride de mise au rail

JG3533

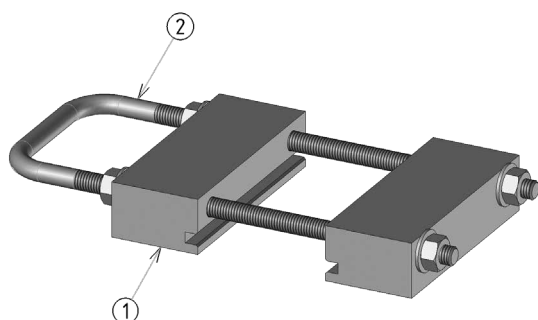

ITEM <i>Repère</i>	QTY <i>Nombre</i>	NAME <i>Désignation</i>	REF <i>Référence</i>
1	2	Support <i>Support</i>	JG3534/202
2	1	Stirrup <i>Etrier</i>	891604

Components_

Pièces détachées

Electric power feed

Bride pour une connexion

JG3640/102

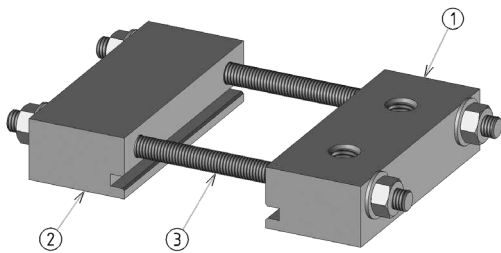

ITEM <i>Repère</i>	QTY <i>Nombre</i>	NAME <i>Désignation</i>	REF <i>Référence</i>
1	1	Drilled part <i>Bloc percé</i>	JG3534/201
2	1	Part <i>Bloc</i>	JG3534/202
3	2	Treaded rod <i>Tige filetée</i>	420462/200

Double electric power feed

Bride pour deux connexions

JG3640/101

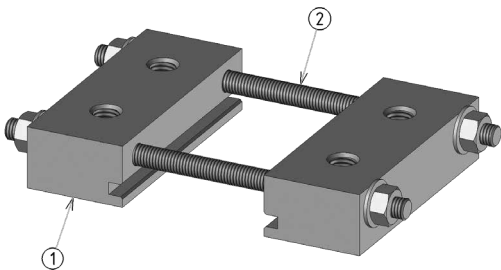

ITEM <i>Repère</i>	QTY <i>Nombre</i>	NAME <i>Désignation</i>	REF <i>Référence</i>
1	2	Drilled part <i>Bloc percé</i>	JG3534/201
2	2	Treaded rod <i>Tige filetée</i>	420462/200

Bridging connection

Connexion de pontage

JG3690/101

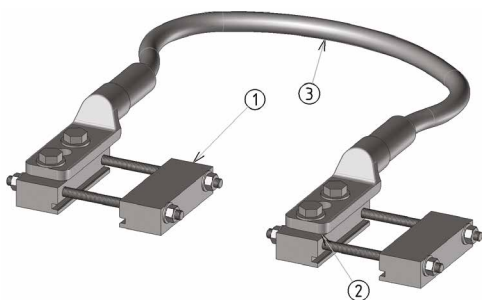

ITEM <i>Repère</i>	QTY <i>Nombre</i>	NAME <i>Désignation</i>	REF <i>Référence</i>
1	2	Connection clamp <i>Bride de connexion</i>	JG3640
2	2	Bimetallic plate <i>Plaque cupal</i>	JG3752
3	1/2	Copper cable and lugs <i>Cable cuivre et cosses</i>	

JG3690/102

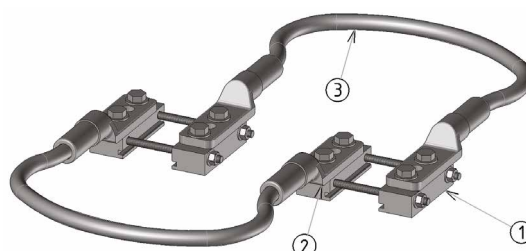

Components_

Pièces détachées

Mid point clamp

Bloc anticheminement

JG3639/101

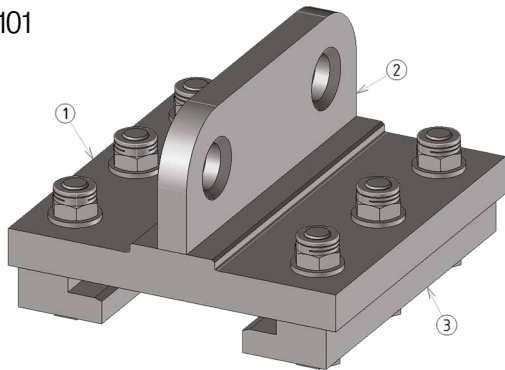

ITEM <i>Repère</i>	QTY <i>Nombre</i>	NAME <i>Désignation</i>	REF <i>Référence</i>
1	2	Part <i>Bloc</i>	JG3537/401
2	1	Lug <i>Tenon</i>	JG3639-1
3	2	Corner plate <i>Equerre</i>	JG3538/103

Mid point clamp - 4 slings

Bloc anticheminement - 4 élingues

JG3639/102

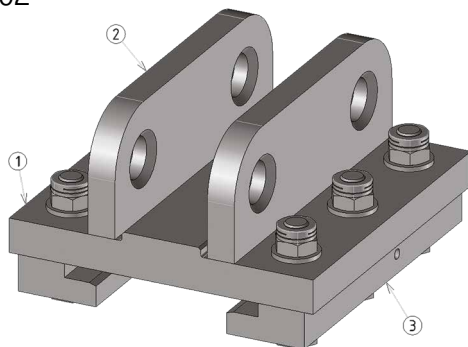

ITEM <i>Repère</i>	QTY <i>Nombre</i>	NAME <i>Désignation</i>	REF <i>Référence</i>
1	2	Part <i>Bloc</i>	JG3537/402
2	2	Lug <i>Tenon</i>	JG3639-1
3	2	Corner plate <i>Equerre</i>	JG3538/103

Anchoring clamp

Bloc d'ancrage

JG3639/201

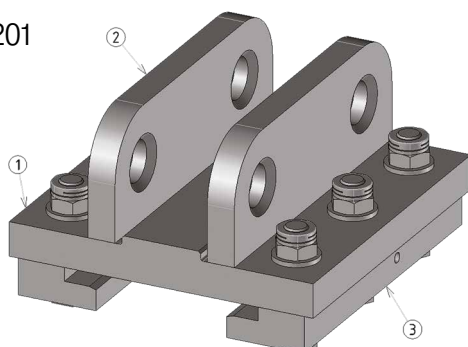

ITEM <i>Repère</i>	QTY <i>Nombre</i>	NAME <i>Désignation</i>	REF <i>Référence</i>
1	2	Part <i>Bloc</i>	JG3537/402
2	2	Lug <i>Tenon</i>	JG3639-1
3	2	Corner plate <i>Equerre</i>	U3538/103

Components_

Pièces détachées

Anchoring sling 25 kV

Élingue d'ancrage 25 kV

ANC1C10-0101

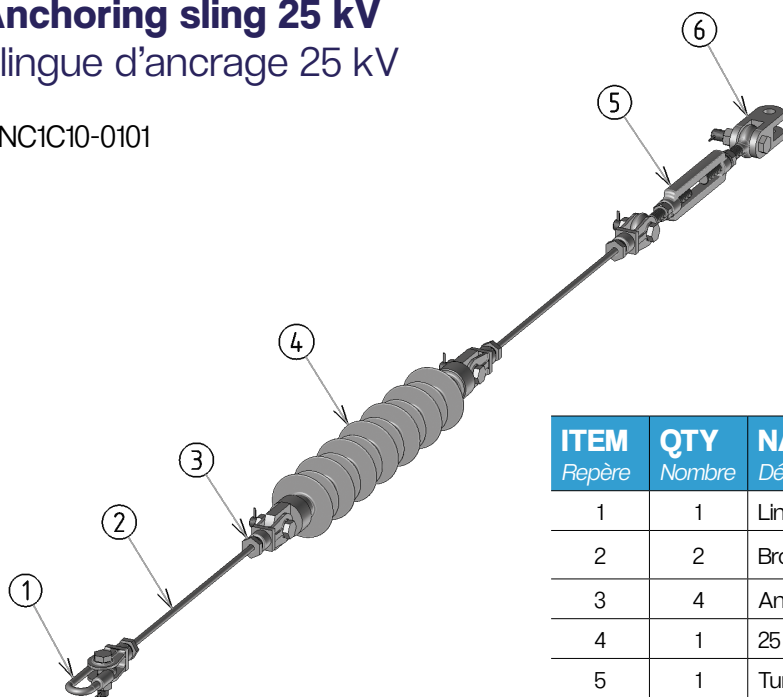

ITEM <i>Repère</i>	QTY <i>Nombre</i>	NAME <i>Désignation</i>	REF <i>Référence</i>
1	1	Link Maillon	N95006
2	2	Bronze cable 65mm ² Câble de Bz 65 mm ²	695054
3	4	Anchor sleeve Manchon d'ancrage	201365
4	1	25 kV insulator Isolateur 25 kV	N51100
5	1	Turnbuckle Tendeur à lanterne	8365
6	1	Anchor clevis Chape d'ancrage	208077

Anchoring sling 25 kV

Élingue d'ancrage 25 kV

ANC1C10-0102

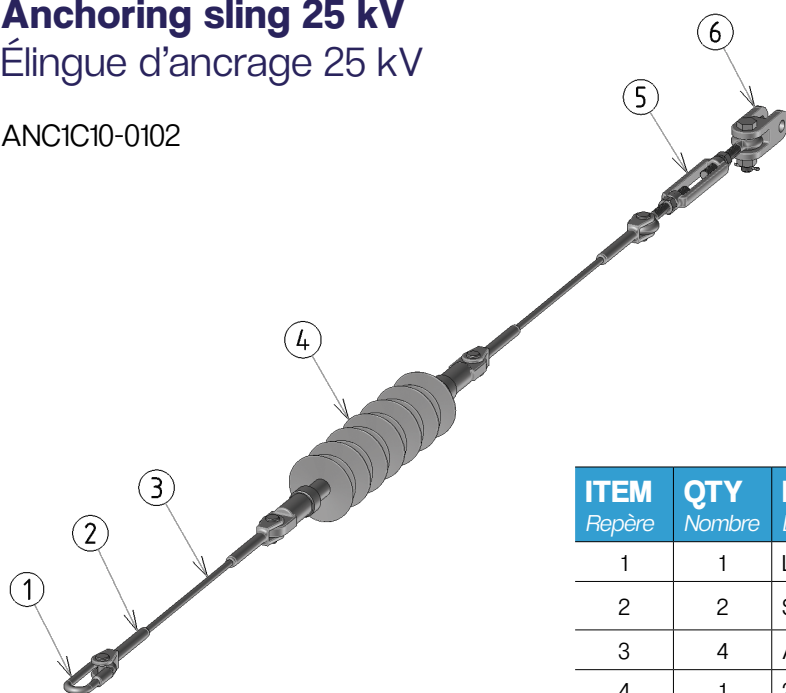

ITEM <i>Repère</i>	QTY <i>Nombre</i>	NAME <i>Désignation</i>	REF <i>Référence</i>
1	1	Link Maillon	N95006
2	2	Stainless steel cable Ø10 Câble inox Ø10	695054
3	4	Anchor sleeve Manchon d'ancrage	N81041
4	1	25 kV insulator Isolateur 25 kV	N51100
5	1	Turnbuckle Tendeur à lanterne	8365
6	1	Anchor clevis Chape d'ancrage	208077

Components_

Pièces détachées

Double insulating anchoring sling

Élingue d'ancrage double isolement

ANC4C6-0301

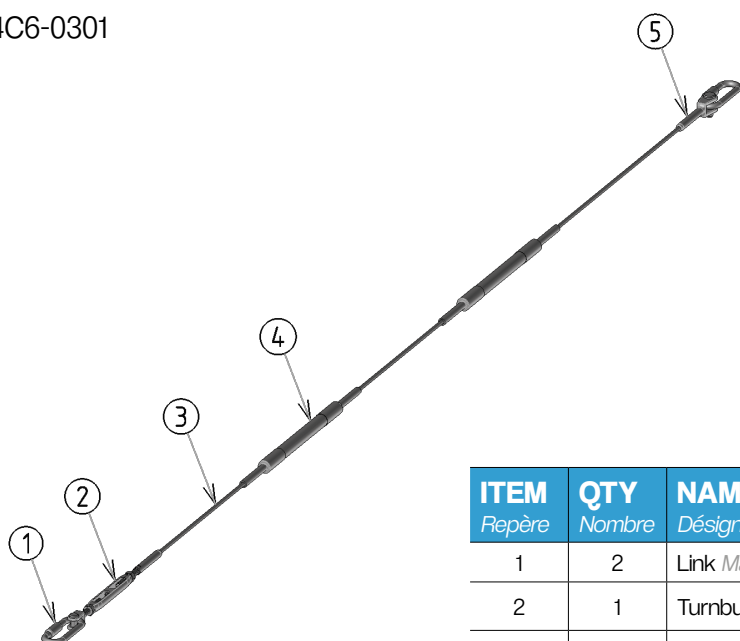

ITEM <i>Repère</i>	QTY <i>Nombre</i>	NAME <i>Désignation</i>	REF <i>Référence</i>
1	2	Link <i>Maillon</i>	N95005
2	1	Turnbuckle <i>Tendeur</i>	N81042
3	3	Stainless steel cable Ø6 <i>Câble inox Ø6</i>	696056
4	2	Insulator <i>Isolateur</i>	JG3050/301
5	1	Crimping sleeve <i>Terminaison sertie</i>	N81039

Protective cover

Capot de protection

JG3644/101



Certification



Partenaires



Contact_

sales@galland-sas.com



Closer to take you further_

ALGERIA
ARGENTINA
AUSTRALIA
BELGIUM
BOSNIA HERZEGOVINA
BRAZIL
BULGARIA
CHINA
CANADA
CHILE
CROATIA
CZECH REPUBLIC
DENMARK
EGYPT
FRANCE
GERMANY
GREECE
HONG KONG
INDIA
IRAN
ISRAEL
ITALY
JAPAN
LITHUANIA
LUXEMBOURG
MALAYSIA
MAURITIUS
MOROCCO
MEXICO
NEW ZEALAND
NORWAY
PERU
POLAND
PORTUGAL
QATAR
ROMANIA
RUSSIA
SENEGAL
SINGAPORE
SWITZERLAND
SOUTH AFRICA
SOUTH KOREA
SPAIN
TAIWAN
THE NETHERLANDS
THE PHILIPPINES
TUNISIA
TURKEY
UNITED ARAB EMIRATES
UNITED KINGDOM
UNITED STATES

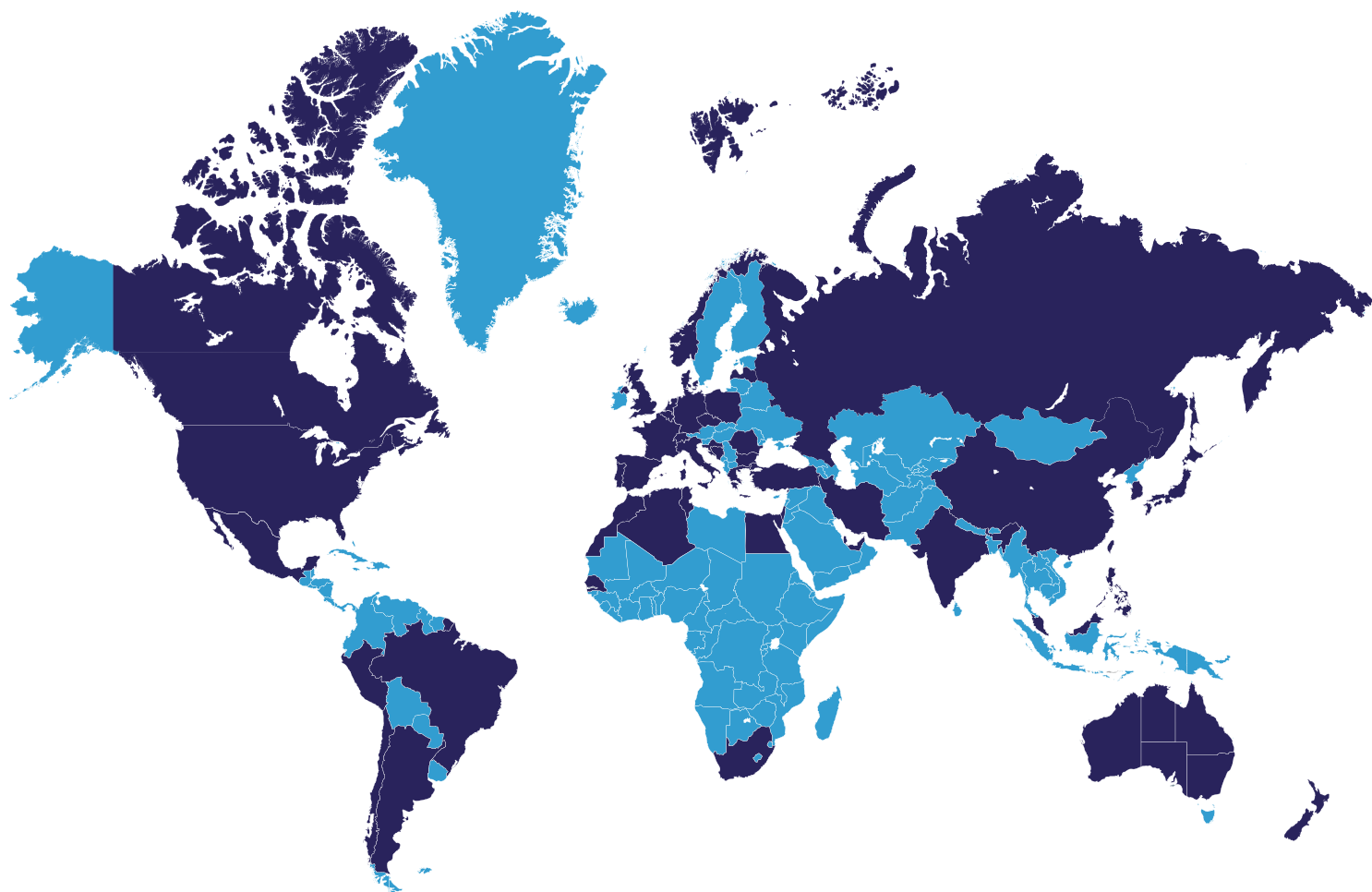

■ GALLAND FOOT PRINT

MARKETING ET COMMUNICATION

galland
CATENARY EXPERTISE
SINCE 1946

GALLAND SAS

255 Z.A. de l'Illet

33240 La Lande-de-Fronsac, France

T. +33 (0)5 57 94 07 20

www.galland-sas.com

