

1500-3000 V DC HIGH-SPEED SECTION INSULATOR_

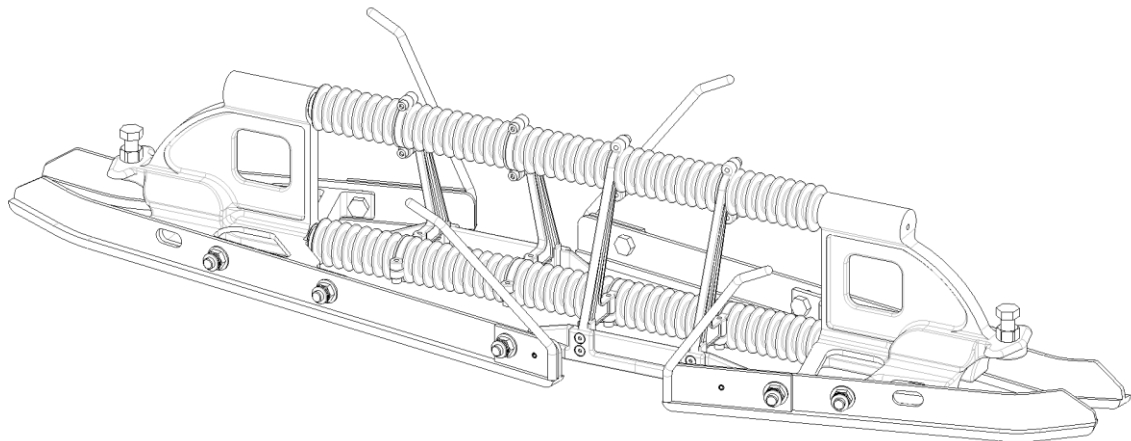

Application

Section insulators (S.I.) are used for the electrical segmentation of the catenary to divide the line in different sections for lines operations and maintenance.

Design

- Speed: up to 200 km/h
- Light and compact
- 1 contact wire

Technical particulars

- 1500 to 3000 V DC
- Weight = 13 kg
- Creepage distance = 1200 mm
- Air gap = 100 mm
- Length = 1080 mm

Option

- With accessories on Messenger Wire (MW) including dropper clamps, collar sockets, insulator.