

1500 V HIGH-SPEED SECTION INSULATOR

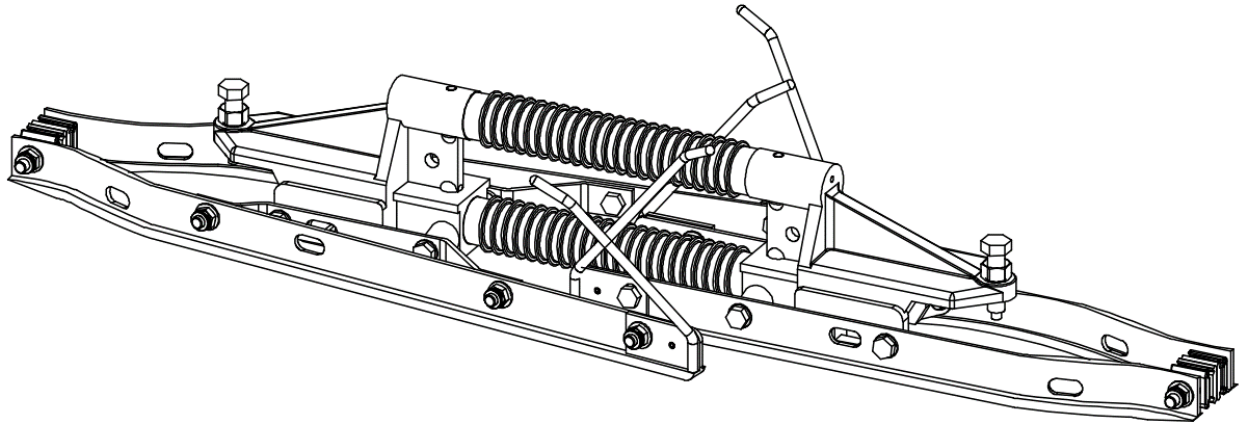

Application

Section insulators (S.I.) are used for the electrical segmentation of the catenary to divide the line in different sections for lines operations and maintenance.

Description

- Mechanical and electrical continuity ensure during dynamic negotiation of the S.I. by the locomotive through metallic runners.
- Version equipped with arcing horns and runners profile on the CW for a better dynamic crossing.
- For one or two contact wires (CW) in BC107, BC120 or BC150 sq.mm according to EN 50149. Alternatively, please contact us by sending design of clamping grooves, CW profile and available standard.
- Negotiation with a preferential way
- Light and compact.

Option

- With accessories on Messenger Wire (MW) including dropper clamps, collar sockets, insulator.