

# MODULAR CANTILEVER SYSTEM MCS-55/70

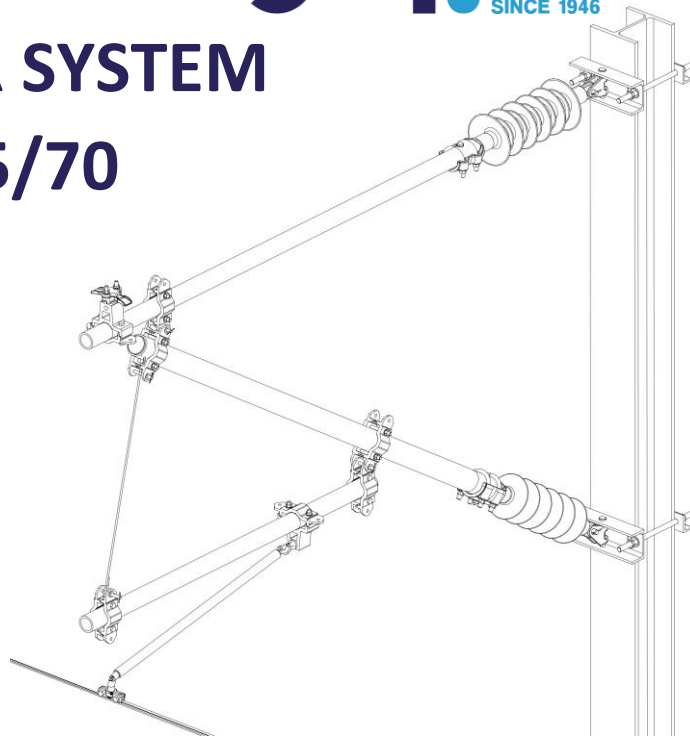

## Application

Cantilevers make the triangulation of the catenary and hold the OHE wires.

Network types:

- Urban mass transit
- Conventional lines
- High-speed

## Description

- Aluminium tubes & fittings
- Tube diameters: Ø55 mm & Ø70 mm
- High level of interchangeability
- Copper aluminium alloy conductor clamps
- Stainless steel fasteners

**Our design office is able to customize the design according to local technical specification.**

**Do not hesitate to contact us for more details or others references ([webcontact@galland-sas.com](mailto:webcontact@galland-sas.com))**

We are fully available to offer turnkey solution for tramway or light-metro cantilevers by covering almost all the components for overhead electrification with possibility to assemble the parts according to individual data sheet per pole.